

DEEPER LIDS ARE AVAILABLE SEE THUMBNAIL

- Note:**
- 1) Material To be 64g/l density (4.0 lb/ft3) EPS, Static Dissipative
  - 2) 1 Degree Draft TYP
  - 3) Dimensions shown are in millimeters

PROPRIETARY AND CONFIDENTIAL  
THE INFORMATION CONTAINED IN THIS DRAWING IS THE SOLE PROPERTY OF TEMPO PLASTIC CO., INC. ANY REPRODUCTION IN PART OR AS A WHOLE WITHOUT THE WRITTEN PERMISSION OF TEMPO PLASTIC CO., INC IS PROHIBITED.

UNLESS OTHERWISE SPECIFIED:		NAME	DATE	TEMPO PLASTIC CO., INC.
DIMENSIONS ARE IN MM		Junior	1/13/26	
TOLERANCES:		DRAWN		TITLE:
FRACTIONAL ±		CHECKED		#15S-6043
ANGULAR: MACH ± BEND ±		ENG APPR.		
TWO PLACE DECIMAL ±		MFG APPR.		SIZE DWG. NO. REV
THREE PLACE DECIMAL ±		Q.A.		D A
INTERPRET GEOMETRIC TOLERANCING PER:		COMMENTS:		SCALE: 1:2 WEIGHT: SHEET 1 OF 2
MATERIAL	FINISH			
NEXT ASSY	USED ON			
APPLICATION	DO NOT SCALE DRAWING			

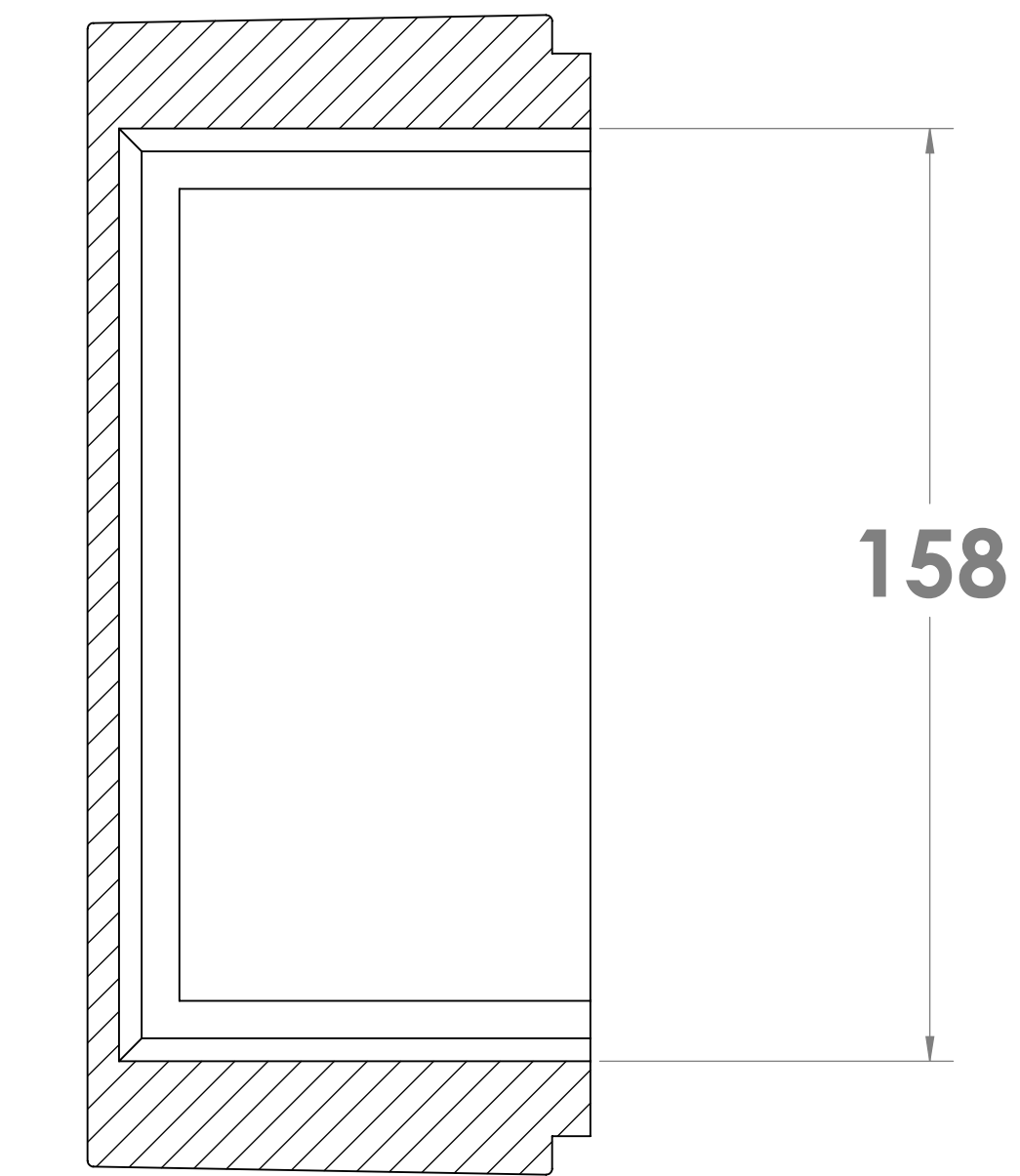
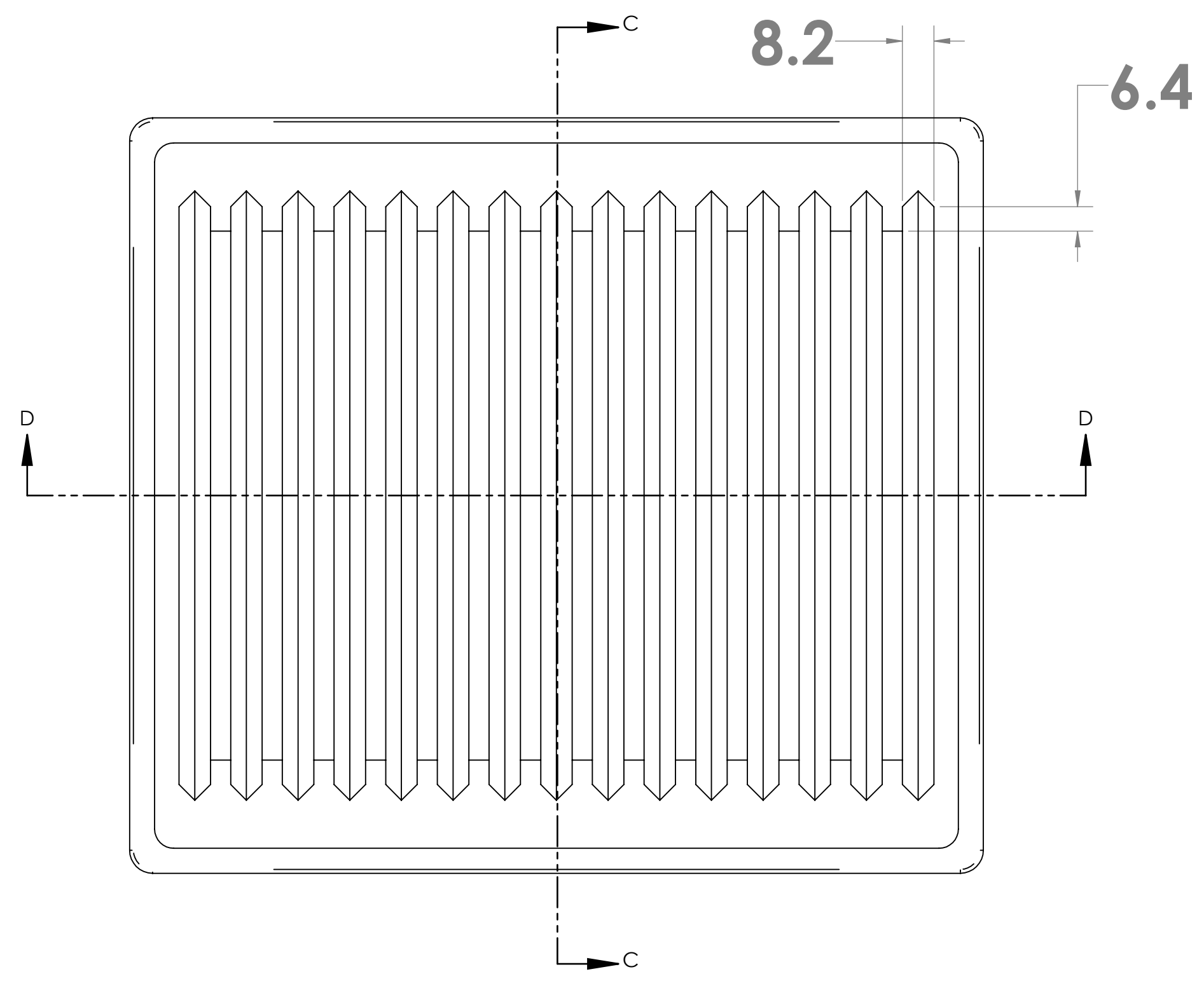

SECTION C-C  
SCALE 1 : 1.25

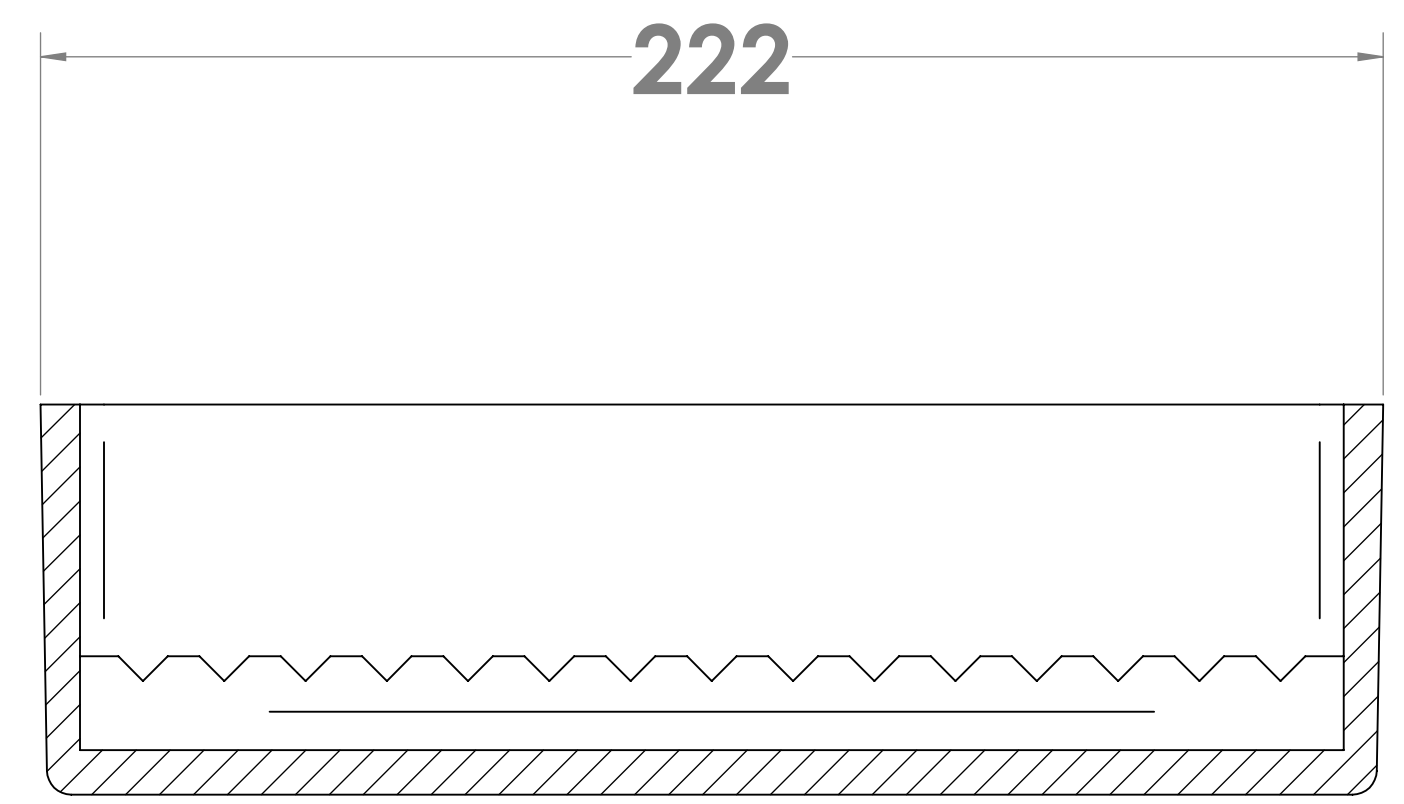

SECTION G-G  
SCALE 1 : 1.25

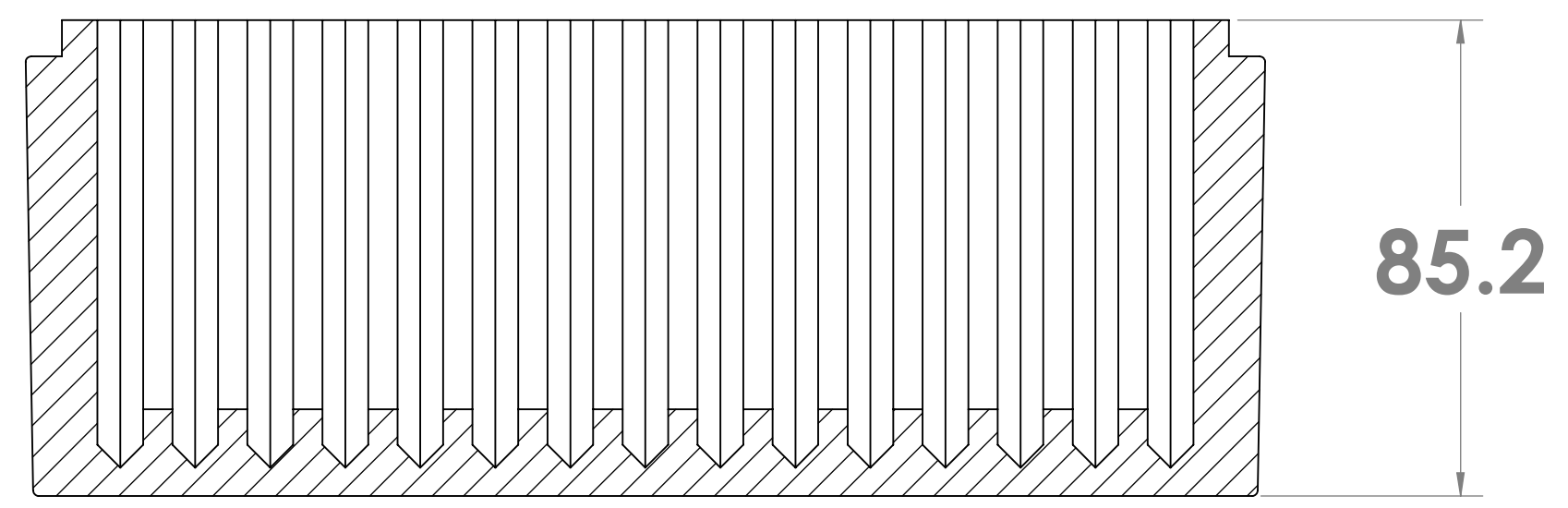

SECTION D-D  
SCALE 1 : 1.25

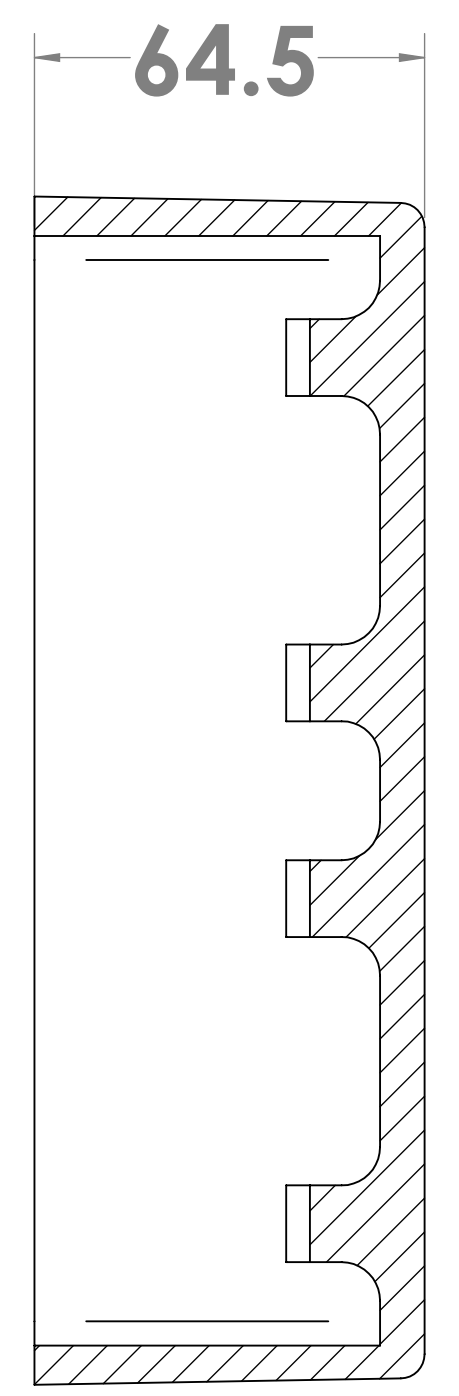

SECTION E-E  
SCALE 1 : 1.25

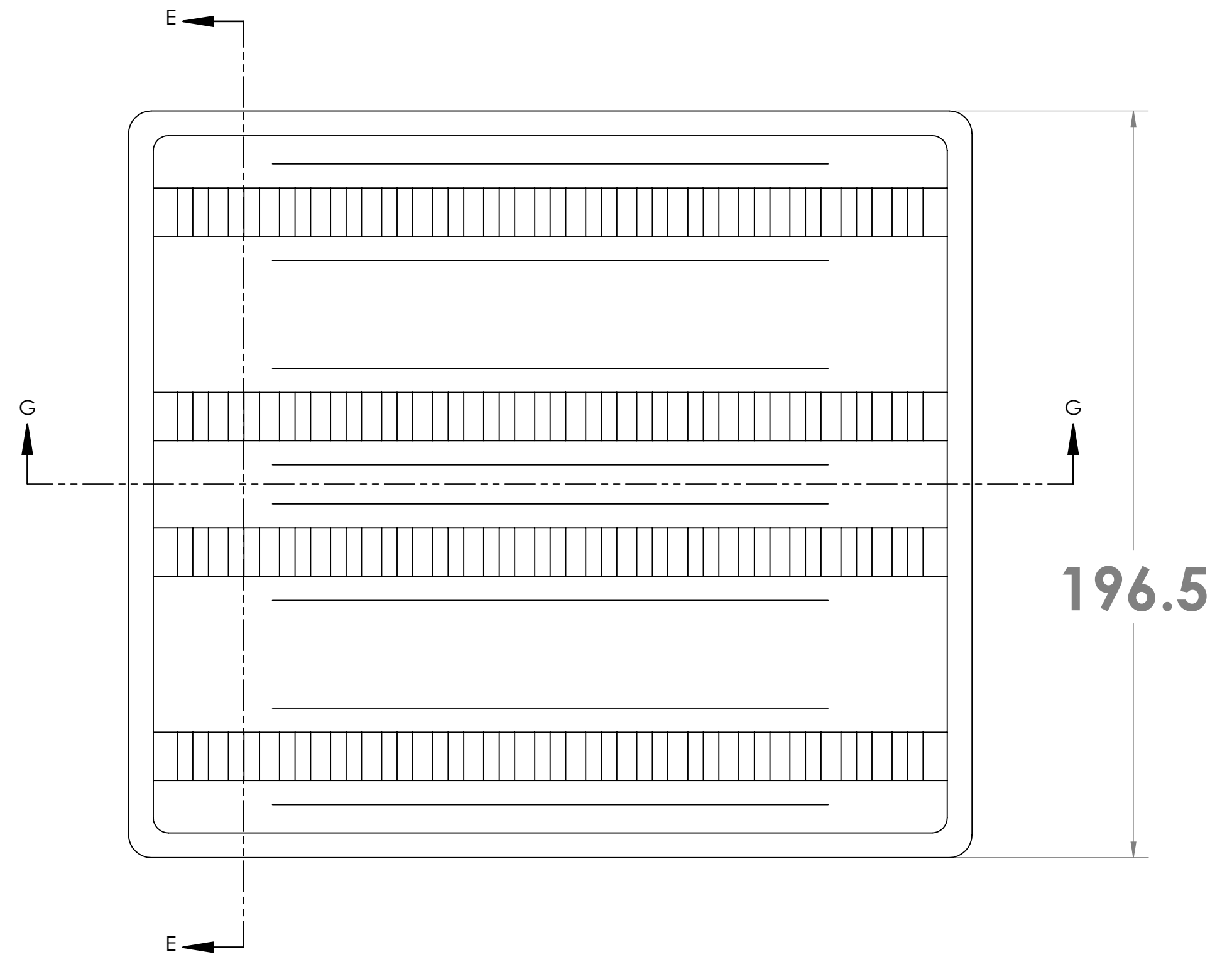

**Note:**  
**1) Material To be 64g/l density (4.0 lb/ft3) EPS, Static Dissipative**  
**2) 1 Degree Draft TYP**  
**3) Dimensions shown are in millimeters**

PROPRIETARY AND CONFIDENTIAL  
 THE INFORMATION CONTAINED IN THIS DRAWING IS THE SOLE PROPERTY OF TEMPO PLASTIC CO., INC. ANY REPRODUCTION IN PART OR AS A WHOLE WITHOUT THE WRITTEN PERMISSION OF TEMPO PLASTIC CO., INC. IS PROHIBITED.

UNLESS OTHERWISE SPECIFIED:		NAME	DATE	TEMPO PLASTIC CO., INC.
DIMENSIONS ARE IN MM		Junior	1/13/26	
TOLERANCES:		DRAWN		TITLE:
FRACTIONAL ±		CHECKED		#15S-6043
ANGULAR: MAACH ± BEND ±		ENG APPR.		SIZE DWG. NO.
TWO PLACE DECIMAL ±		MFG APPR.		D
THREE PLACE DECIMAL ±		Q.A.		REV
INTERPRET GEOMETRIC TOLERANCING PER:		COMMENTS:		
MATERIAL:				
FINISH:				
NEXT ASSY	USED ON			SCALE: 1:2 WEIGHT: SHEET 2 OF 2
APPLICATION	DO NOT SCALE DRAWING			