

A208 50R2300 LID

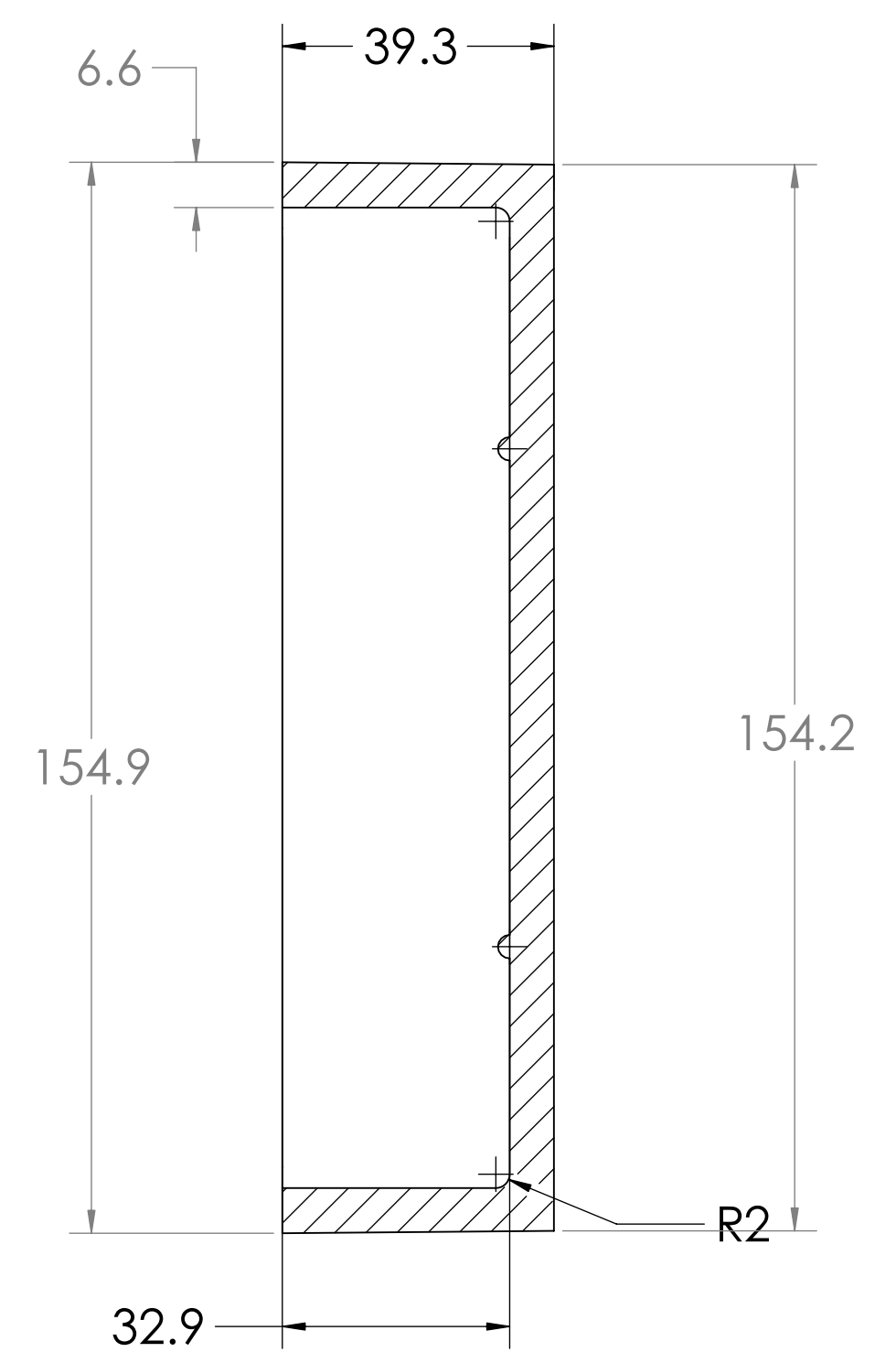

SECTION E-E

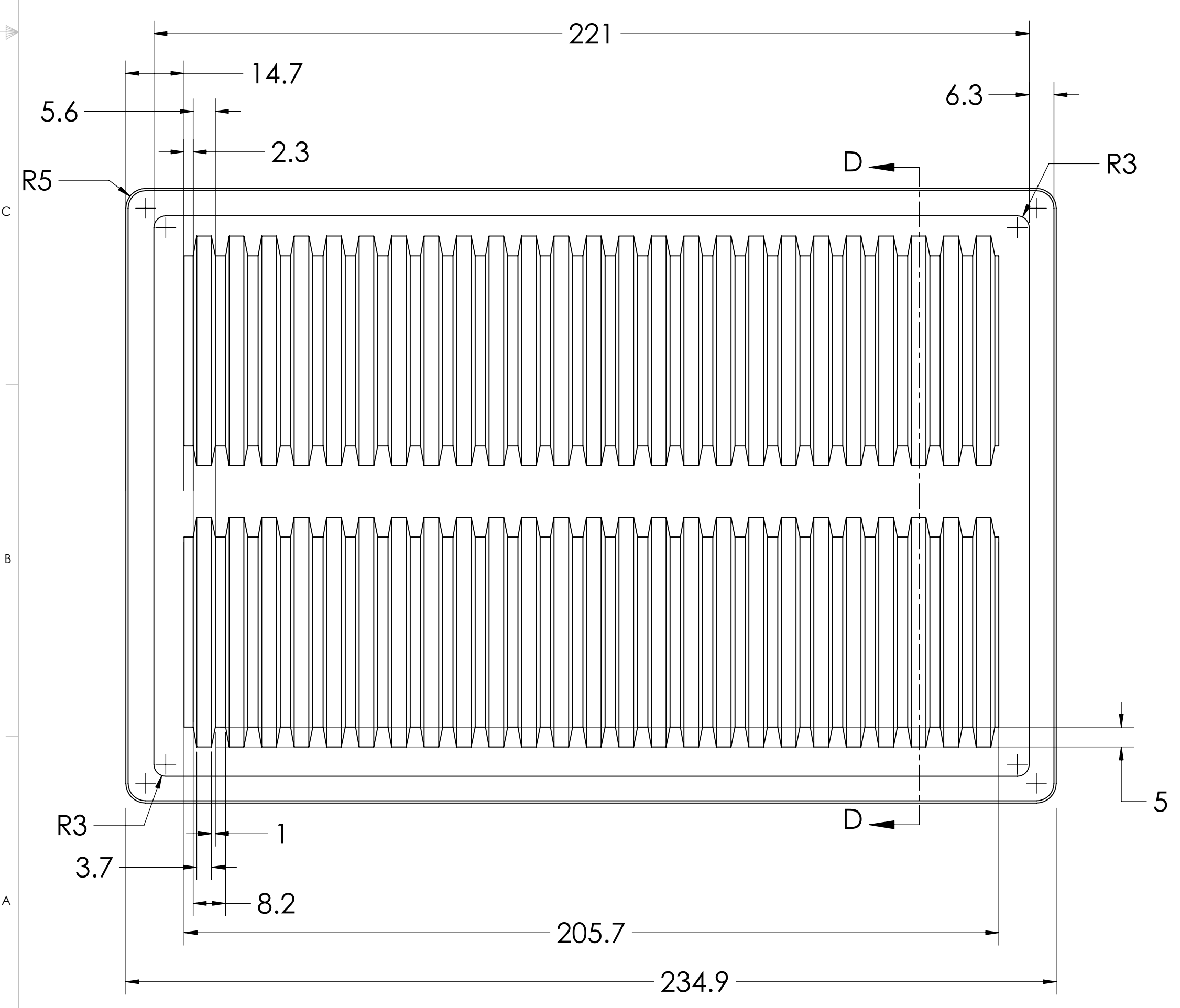
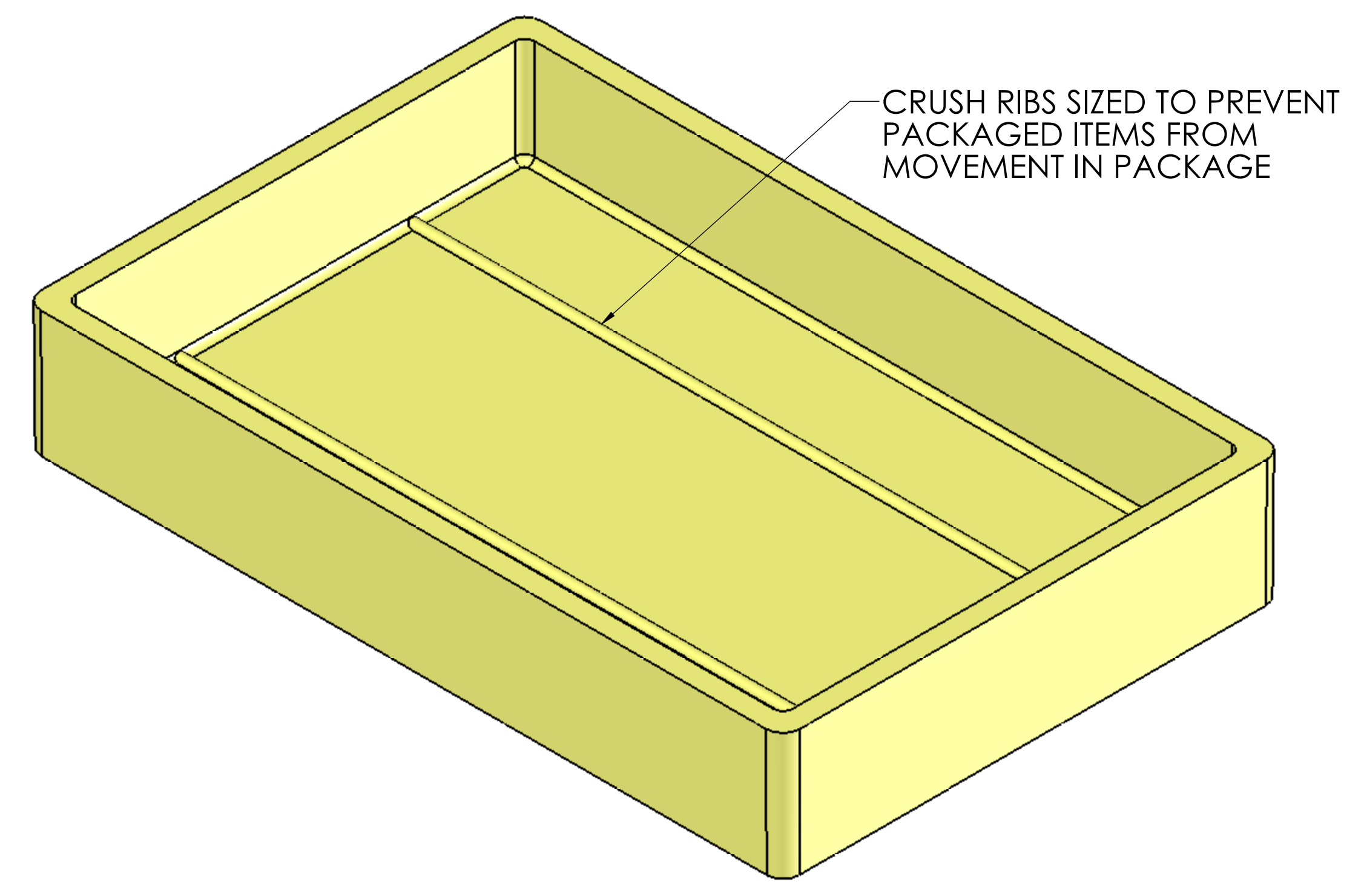

A208 50R2300 BASE

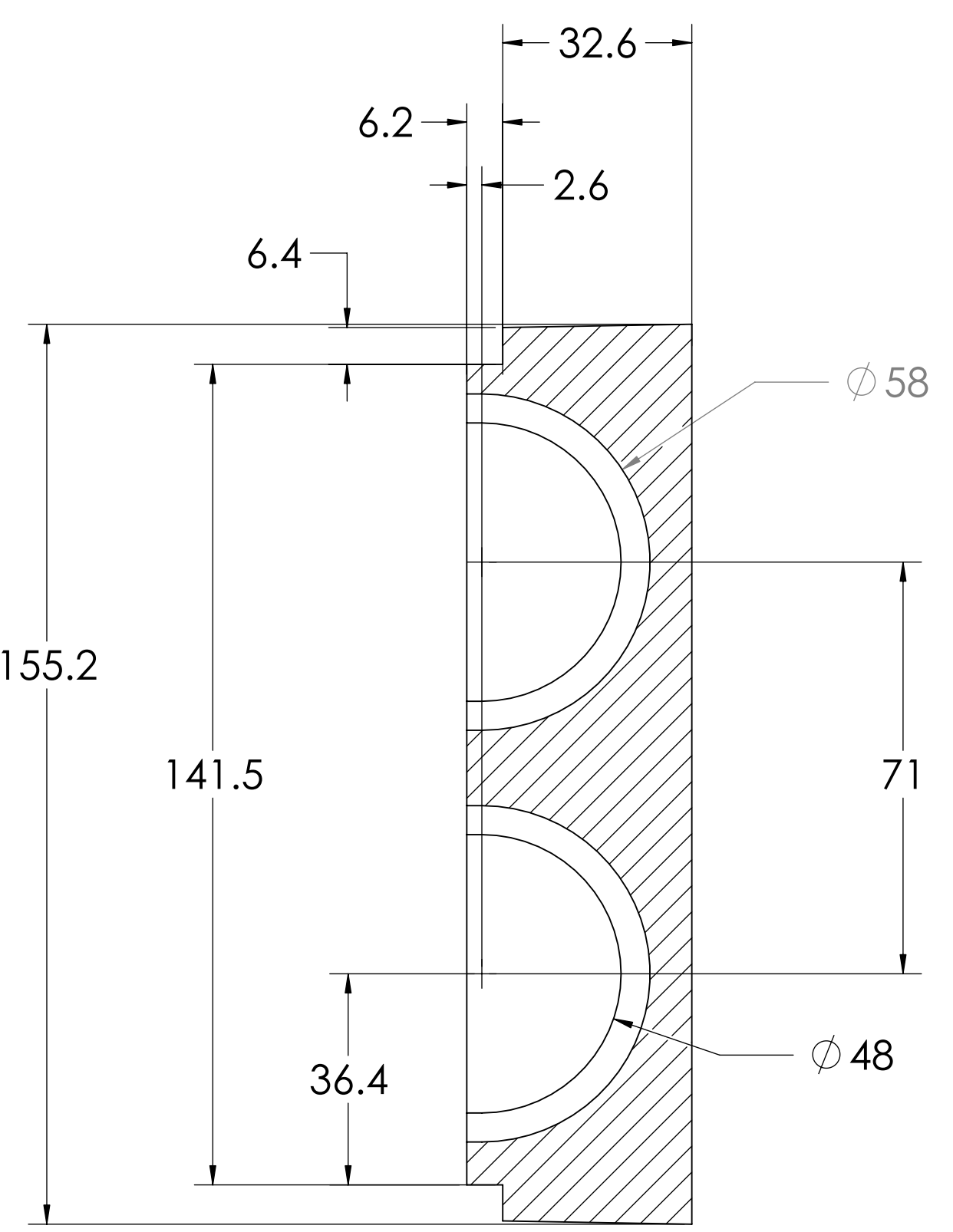

SECTION D-D

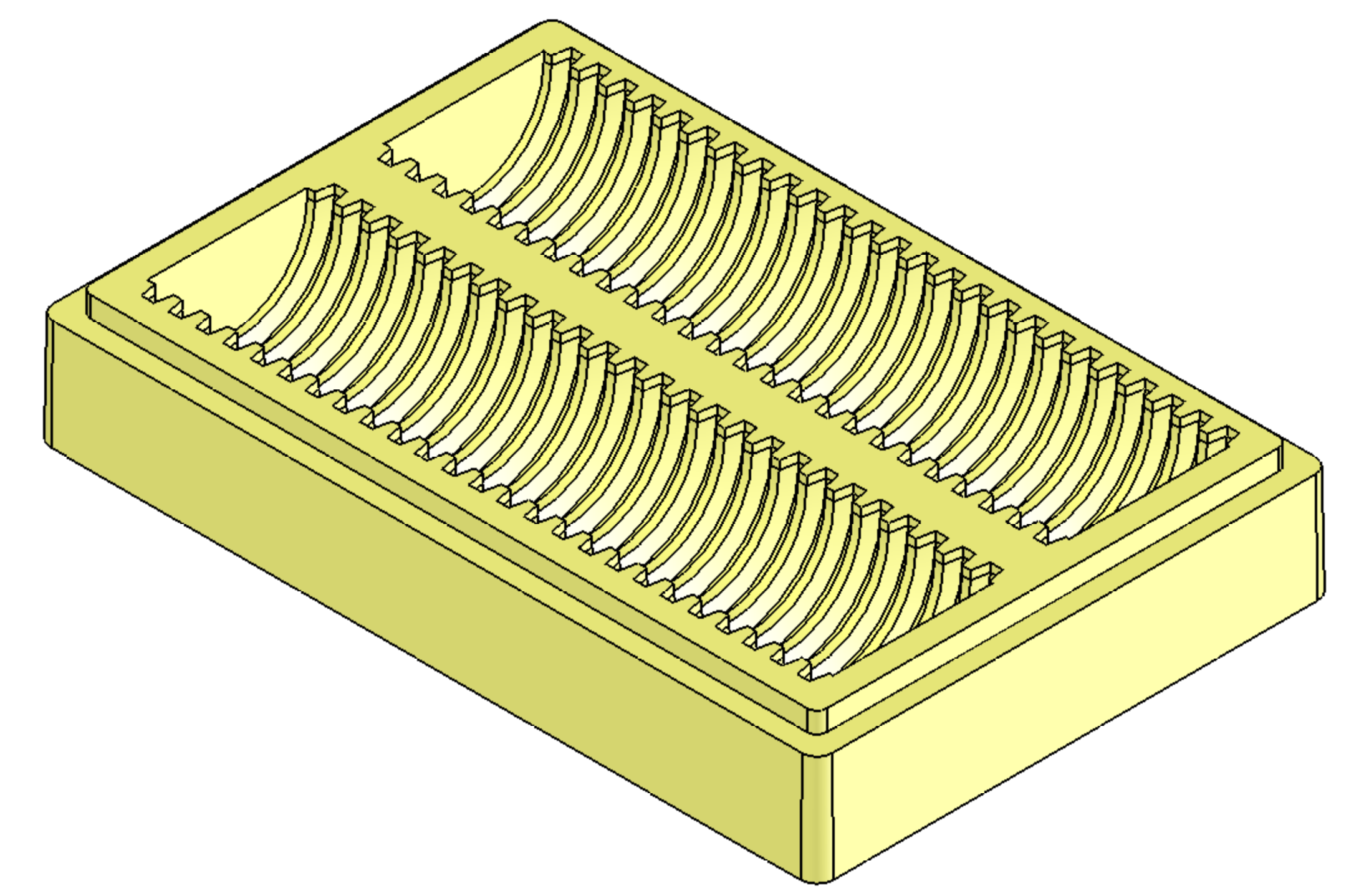

Note:

- 1) Material To be g/l density ( lb/ft3) EPS W/Anti-Stat
- parts to weigh g minimum
- 2) 1 Degree Draft TYP
- 3) Volume = cubic inches
- 4) Check flatness on layout table

PROPRIETARY AND CONFIDENTIAL  
 THE INFORMATION CONTAINED IN THIS DRAWING IS THE SOLE PROPERTY OF Tempco Plastics Co., Inc. ANY REPRODUCTION IN PART OR AS A WHOLE WITHOUT THE WRITTEN PERMISSION OF Tempco Plastics Co., Inc IS PROHIBITED.

UNLESS OTHERWISE SPECIFIED:		NAME	DATE
DIMENSIONS ARE IN Millimeters		J Ellis	20Jun06
TOLERANCES:			
FRACTIONAL ±	CHECKED		
ANGULAR MATCH ±	ENG APPR: D Rogers	20Jun06	
BEND ±	MFG APPR:		
TWO PLACE DECIMAL ±	G.A.		
THREE PLACE DECIMAL ±	COMMENTS:		
INTERPRET GEOMETRIC TOLERANCING PER:			
MATERIAL: Dry Molded EPS			
See note 1			
NEXT ASSY	USED ON		
APPLICATION			

TITLE: A208 50R2300 BASE & LID		
SIZE	DWG. NO.	REV
D	062006JRE	A
SCALE: 1:1.5	SHEET 1 OF 1	