

4.3

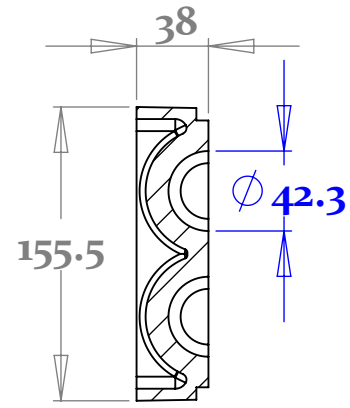

SECTION A-A
SCALE 1 : 4

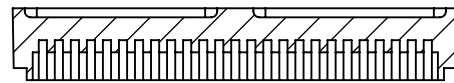

SECTION B-B
SCALE 1 : 4

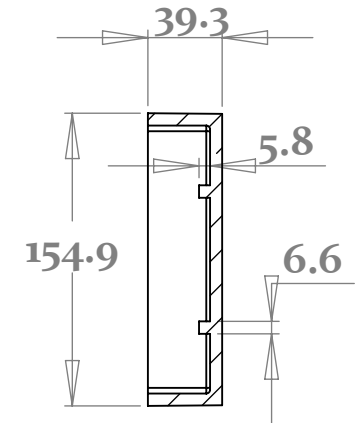
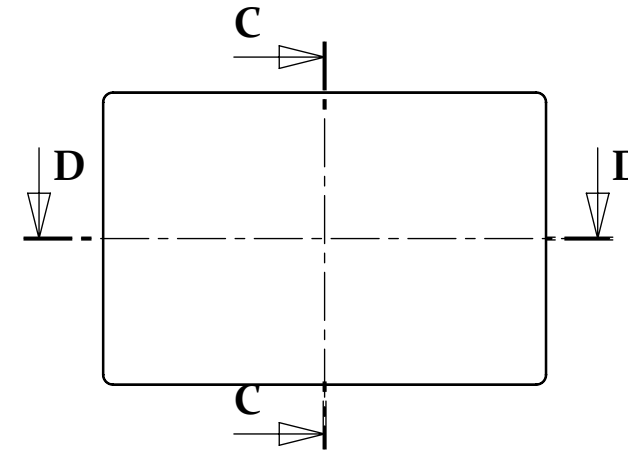

SECTION C-C
SCALE 1 : 4

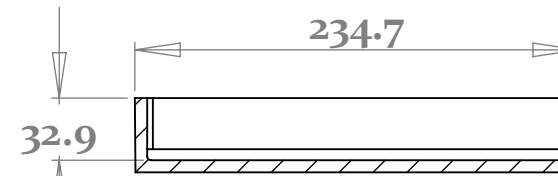

SECTION D-D
SCALE 1 : 4

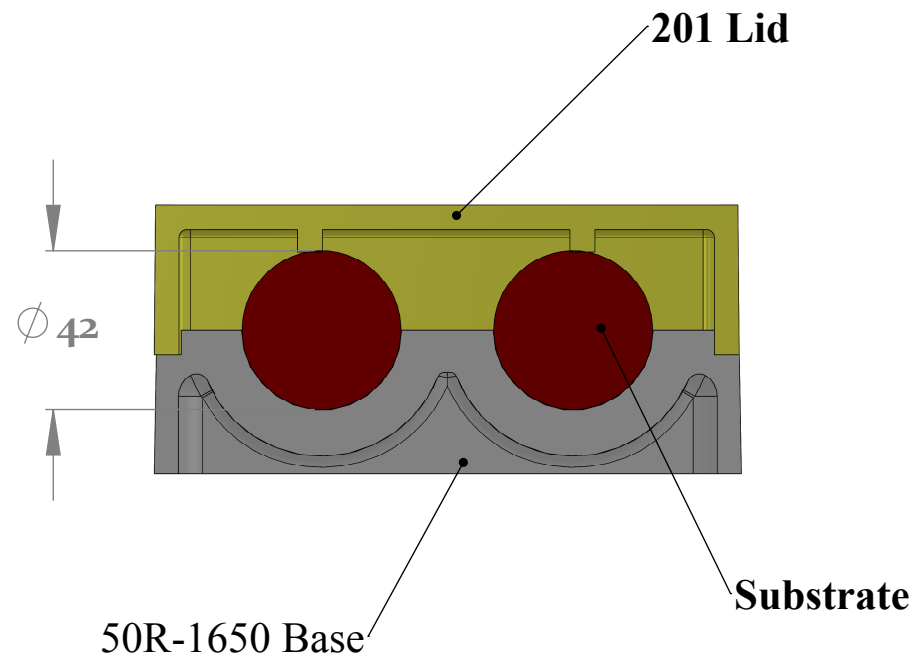

50R-1650

Base

Lid

Date: _____ Insp: _____

Note:

- 1) Material To be 64g/l density (4.0 lb/ft³)
Static Dissipative EPS
- 2) 1 Degree Draft TYP
- 3)

PROPRIETARY AND CONFIDENTIAL
THE INFORMATION CONTAINED IN THIS DRAWING IS THE SOLE PROPERTY OF TEMPO PLASTIC CO, INC. ANY REPRODUCTION IN PART OR AS A WHOLE WITHOUT THE WRITTEN PERMISSION OF TEMPO PLASTIC CO, INC. IS PROHIBITED.

		UNLESS OTHERWISE SPECIFIED:		NAME	DATE	TEMPO PLASTIC CO, INC.	
		DIMENSIONS ARE IN MM		DRAWN	JUNIOR	1/16/15	TITLE: 50R-1650
		TOLERANCES:		CHECKED			
		FRACTIONAL ±		ENG APPR.			
		ANGULAR: MACH ± BEND ±		MFG APPR.			
		TWO PLACE DECIMAL ±		Q.A.			SIZE DWG. NO. REV B _____ A
		THREE PLACE DECIMAL ±		COMMENTS:			
		INTERPRET GEOMETRIC TOLERANCING PER:					SCALE: 1:2
		MATERIAL					SHEET 1 OF 1
		FINISH					
NEXT ASSY	USED ON	DO NOT SCALE DRAWING					
APPLICATION							