

SECTION A-A
SCALE 1 : 1.75

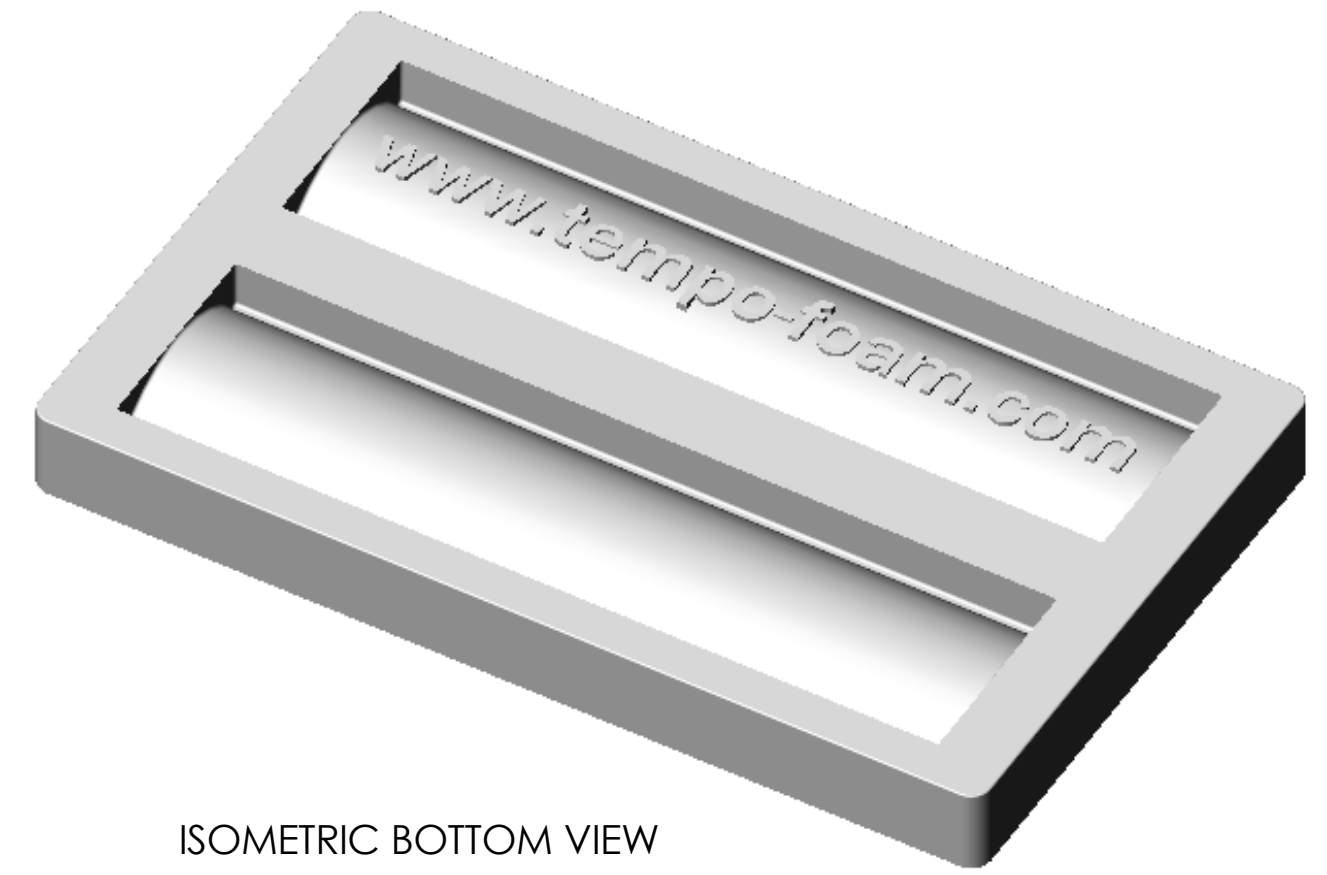

ISOMETRIC BOTTOM VIEW

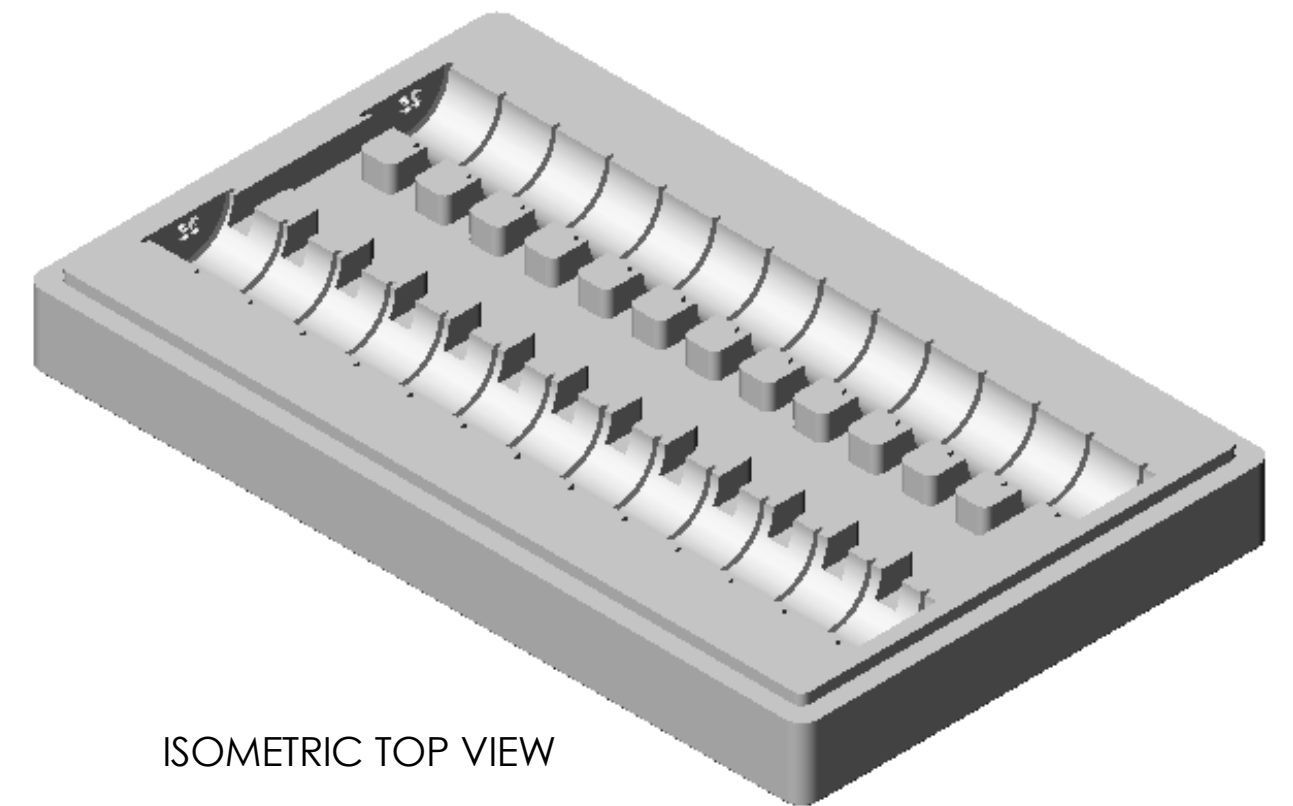

ISOMETRIC TOP VIEW

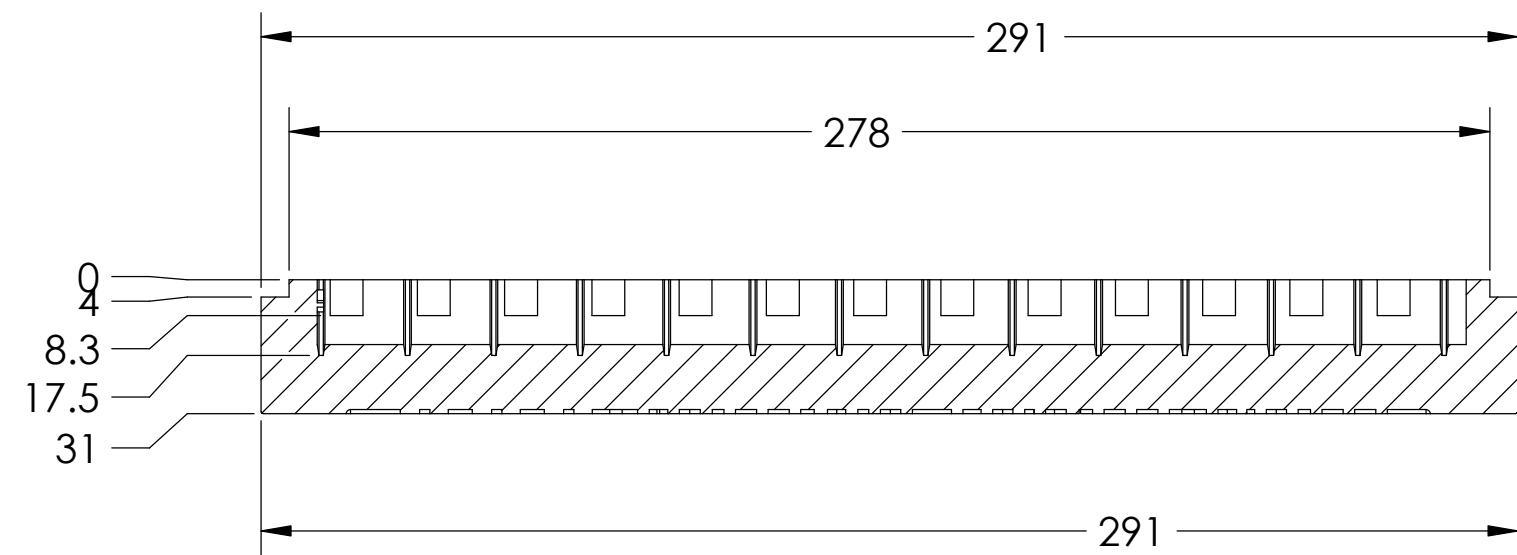

SECTION B-B
SCALE 1 : 1.75

NOTES:

- 1- MATERIAL: DRY MOLDED POLYSTYRENE, 63 gm/liter
- 2- ALL DIMENSIONS ARE IN MILLIMETERS
- 3- WEIGHT: 70.8 gm
- 4- VOLUME: 1108.9 CU CENTIMETERS

PROPRIETARY AND CONFIDENTIAL
THE INFORMATION CONTAINED IN THIS DRAWING IS THE SOLE PROPERTY OF TEMPO PLASTIC CO., INC. ANY REPRODUCTION IN PART OR AS A WHOLE WITHOUT THE WRITTEN PERMISSION OF TEMPO PLASTIC CO., INC. IS PROHIBITED.

UNLESS OTHERWISE SPECIFIED:		NAME	DATE	TEMPO PLASTIC CO., INC. 1227 N. MILLER PARK COURT VISALIA, CA 93291
DIMENSIONS ARE IN INCHES		DRAWN	J ELLIS	
TOLERANCES:		CHECKED	DBR	29Dec04
FRACTIONAL ±		ENG APPR.		
ANGULAR: MATCH ± BEND ±		MFG APPR.	DBR	29Dec04
TWO PLACE DECIMAL ±		Q.A.		
THREE PLACE DECIMAL ±		COMMENTS:		
INTERPRET GEOMETRIC TOLERANCING PER:				
MATERIAL:				
FINISH:				
NEXT ASSY	USED ON			
APPLICATION	DO NOT SCALE DRAWING			
TITLE:				35 mm CW PKG BASE
SIZE	DWG. NO.	REV		
C	122904JRE			
SCALE: 1:2	WEIGHT:	SHEET 1 OF 1		