

4

3

2

1

B

A

B

A

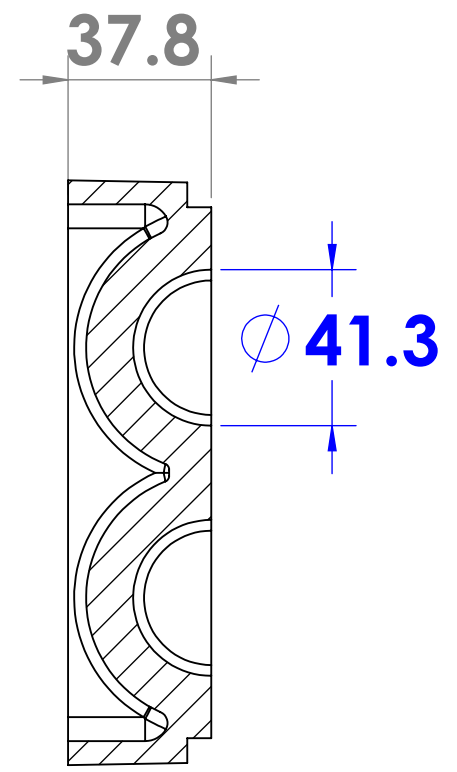
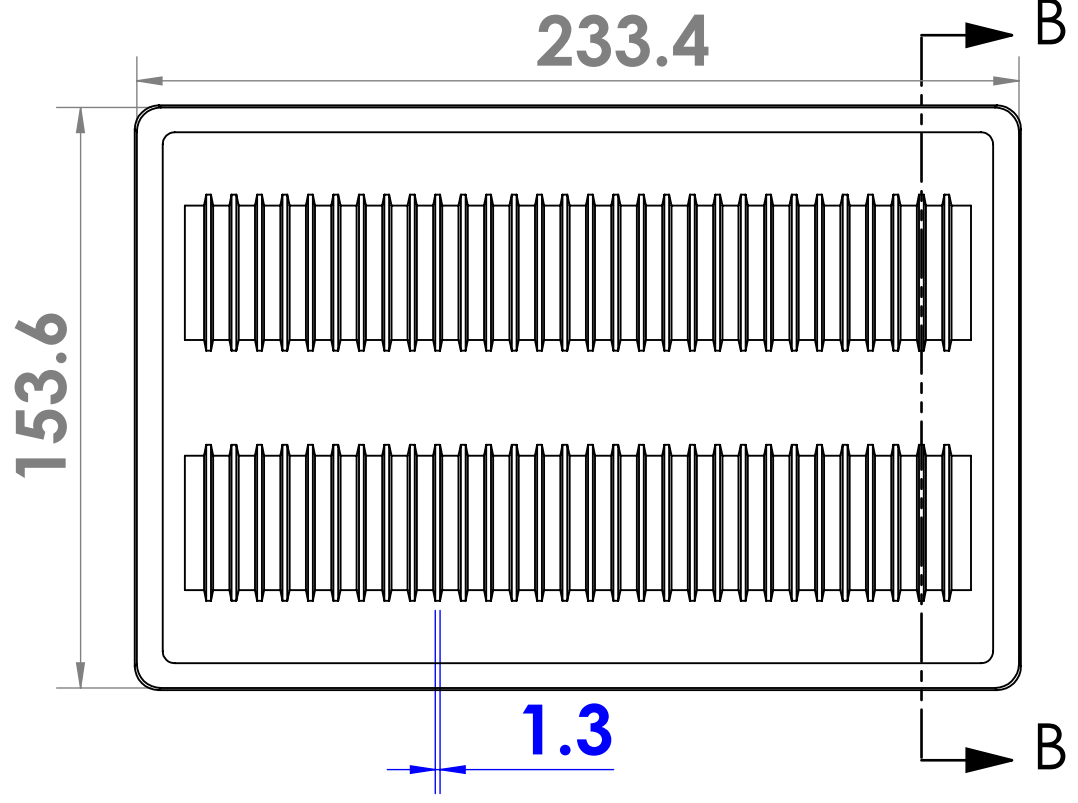

SECTION B-B

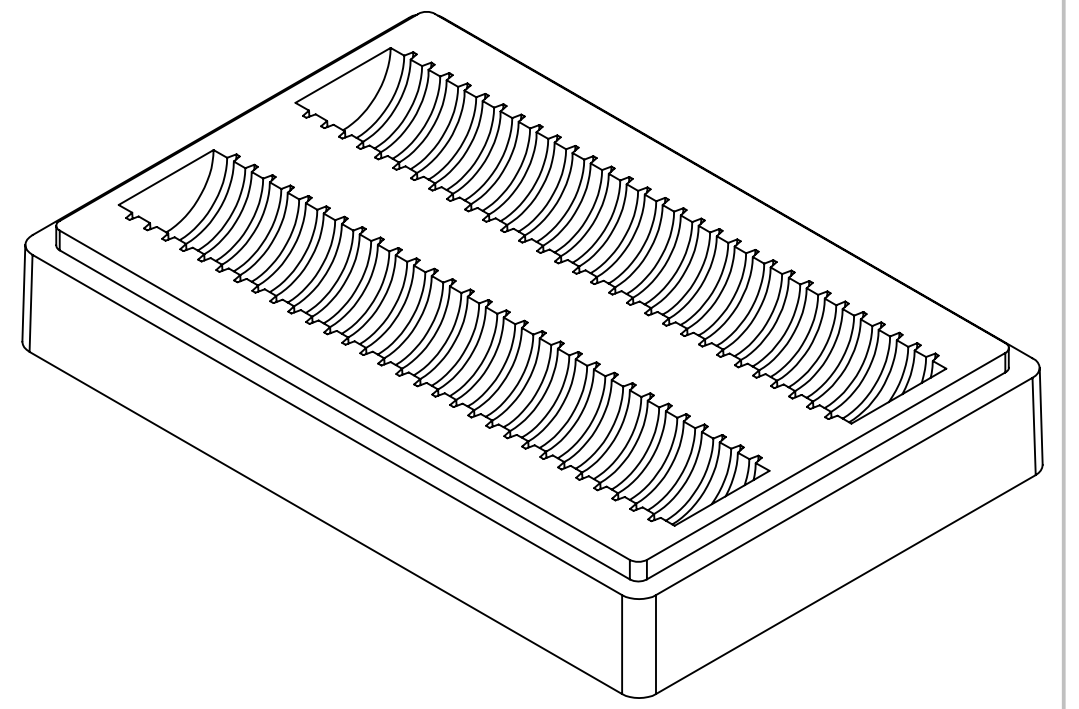

Note:
 1) Material To be 64g/l density (4.0 lb/ft³)
 Static Dissipative EPS
 2) 1 Degree Draft TYP

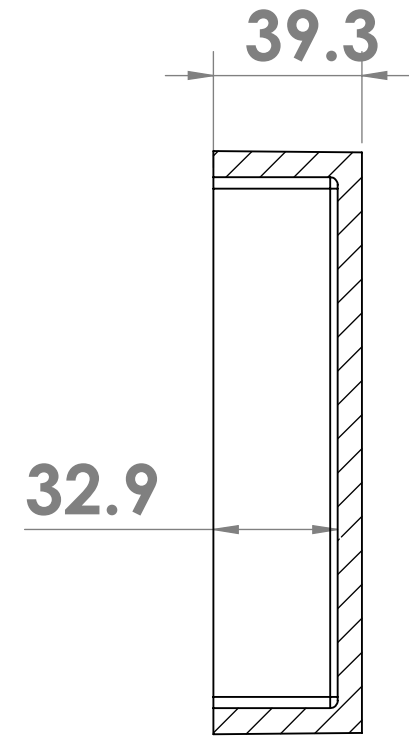
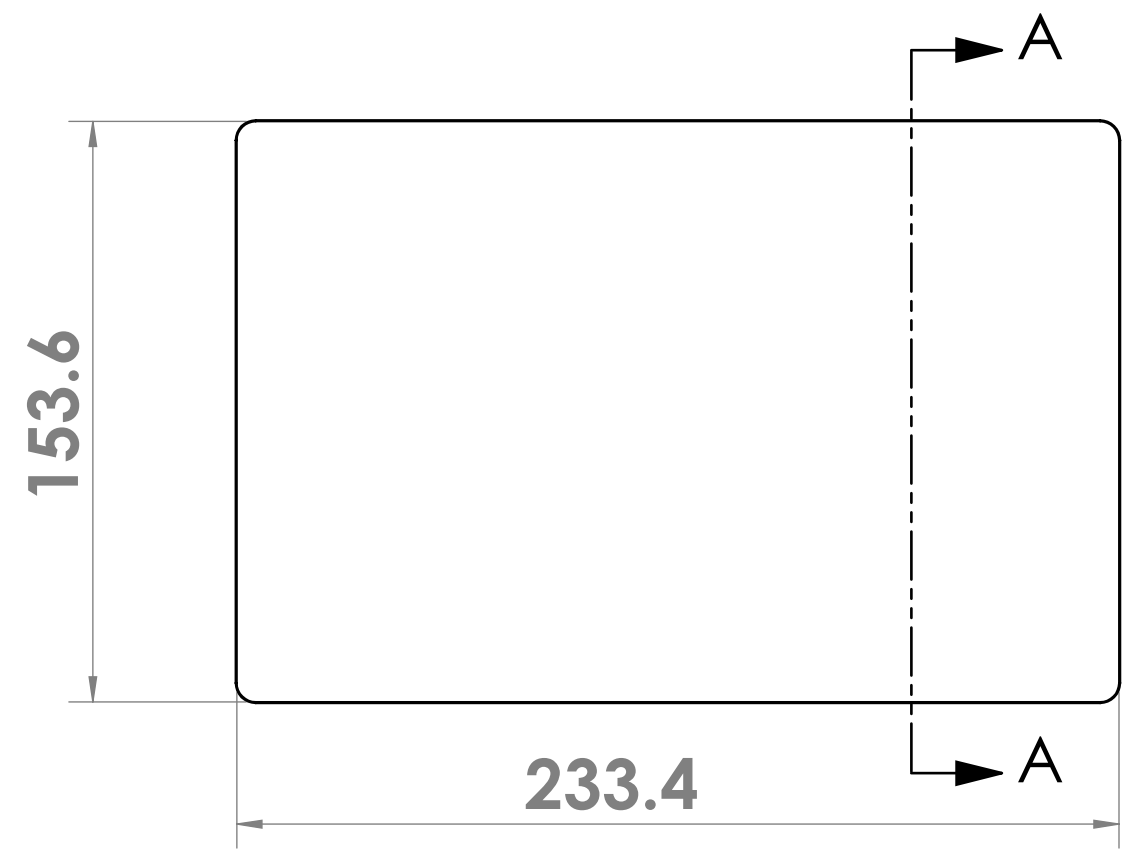

SECTION A-A

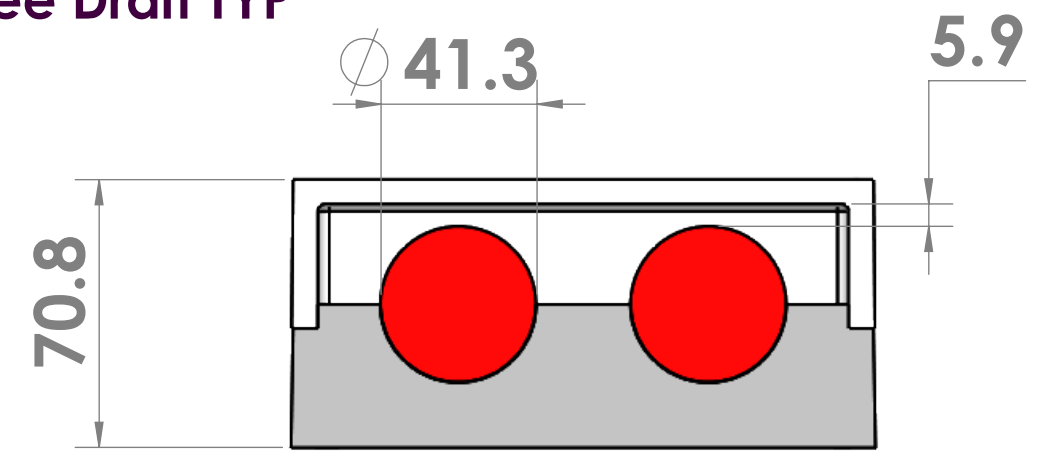

PROPRIETARY AND CONFIDENTIAL
 THE INFORMATION CONTAINED IN THIS DRAWING IS THE SOLE PROPERTY OF <INSERT COMPANY NAME HERE>. ANY REPRODUCTION IN PART OR AS A WHOLE WITHOUT THE WRITTEN PERMISSION OF <INSERT COMPANY NAME HERE> IS PROHIBITED.

UNLESS OTHERWISE SPECIFIED:	NAME	DATE
DIMENSIONS ARE IN INCHES	Jr	1/7/25
TOLERANCES:		
FRACTIONAL ±		
ANGULAR: MACH ± BEND ±		
TWO PLACE DECIMAL ±		
THREE PLACE DECIMAL ±		
INTERPRET GEOMETRIC TOLERANCING PER:		
MATERIAL		
FINISH		
APPLICATION		
DO NOT SCALE DRAWING		

DRAWN	
CHECKED	
ENG APPR.	
MFG APPR.	
Q.A.	
COMMENTS:	

Tempo Plastic Co.		
TITLE:		
60R-1625		
SIZE	DWG. NO.	REV
B		A
SCALE: 1:2	WEIGHT:	SHEET 1 OF 1

4

3

2

1