

1.4

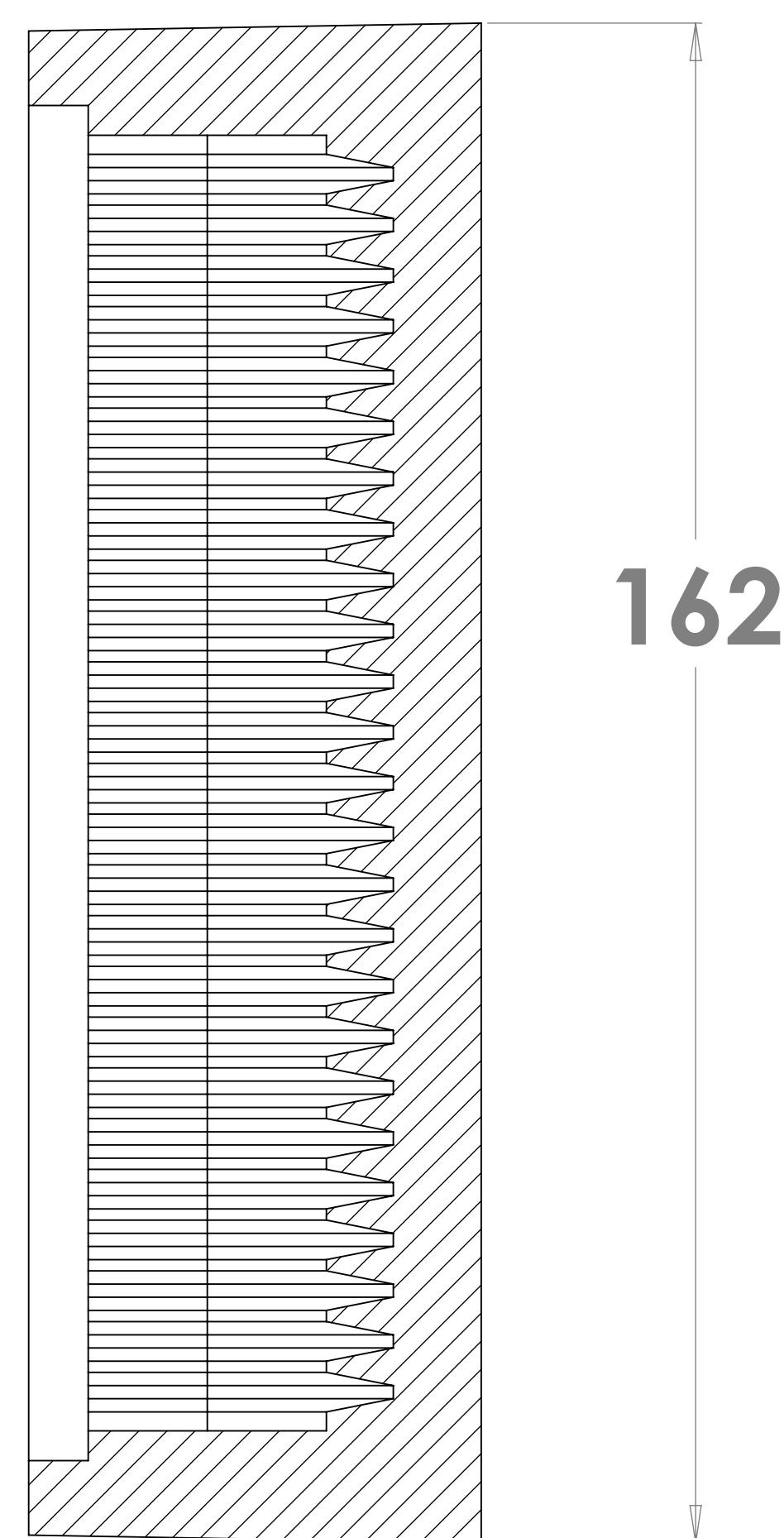

SECTION B-B  
SCALE 1.5 : 1

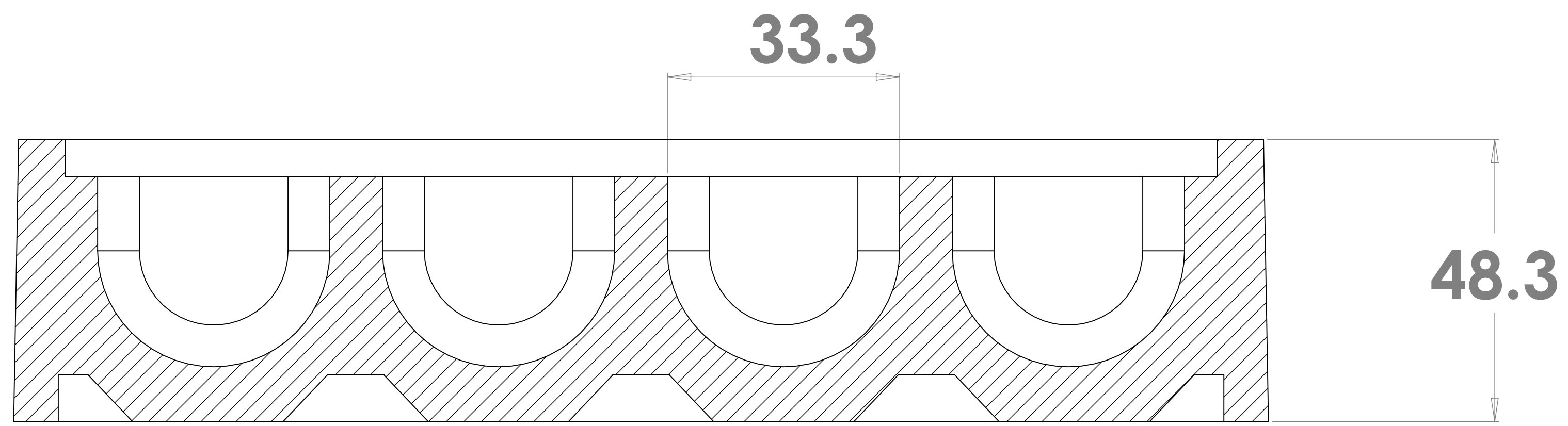

SECTION A-A  
SCALE 1.5 : 1

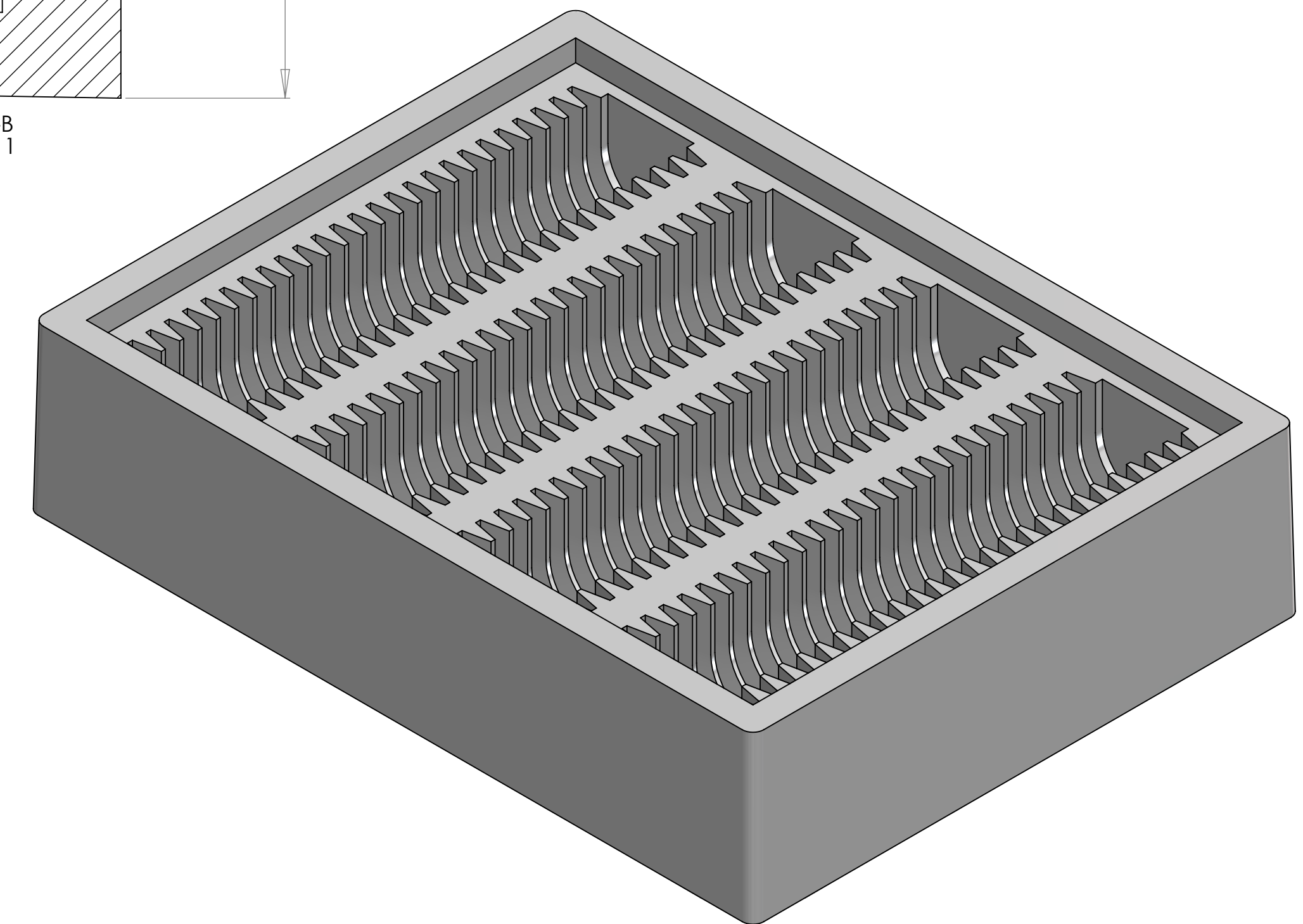

**Note:**  
 1) Material To be 64g/l density (4.0 lb/ft<sup>3</sup>) EPS,  
 Static Dissipative  
 2) 1 Degree Draft TYP

PROPRIETARY AND CONFIDENTIAL  
 THE INFORMATION CONTAINED IN THIS  
 DRAWING IS THE SOLE PROPERTY OF  
 Tempo Plastic Co., Inc. ANY  
 REPRODUCTION IN PART OR AS A WHOLE  
 WITHOUT THE WRITTEN PERMISSION OF  
 Tempo Plastic Co., Inc IS  
 PROHIBITED.

UNLESS OTHERWISE SPECIFIED:		DRAWN	NAME	DATE	Tempo Plastic Co., Inc.
DIMENSIONS ARE IN Millimeters		JR	JR	3/22/19	
TOLERANCES:		CHECKED			
FRACTIONAL ±		ENG APPR.			
ANGULAR MATCH ±		MFG APPR.			
BEND ±		G.A.			
TWO PLACE DECIMAL ±		COMMENTS:			
THREE PLACE DECIMAL ±					
INTERPRET GEOMETRIC TOLERANCING PER:					
MATERIAL					
NEXT ASSY	USED ON	FINISH			SIZE DWG. NO. REV
APPLICATION					<b>D</b> 1 1
					SCALE: 2:1 SHEET 1 OF 1